Dynamic Reconfiguration in NoC-based MPSoCs in the Avionics Domain

Robert Hilbrich
Reinier van Kampenhout



Multi-Core Processors in the Avionics Domain

Avionic industry with its long development cycles is interested in adopting multi-core processors.

Main drivers are:

- Concentration of the same functionality on fewer devices to reduce:
 - weight
 - power
 - costs
- Interest in simple cores to improve predictability
- Higher performance as a result of parallelization

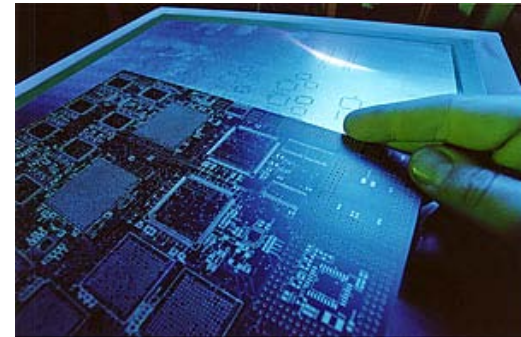

Avionic Software Characteristics

- Trend towards a shared computing platform (Integrated Modular Avionics)
- Necessary: time and space partitioning to achieve isolation (ARINC 653)
- Functionality is implemented in tasks:
 - synchronous (fixed period) and asynchronous (data-driven, event-driven)
 - varying criticality levels (Design Assurance Level)

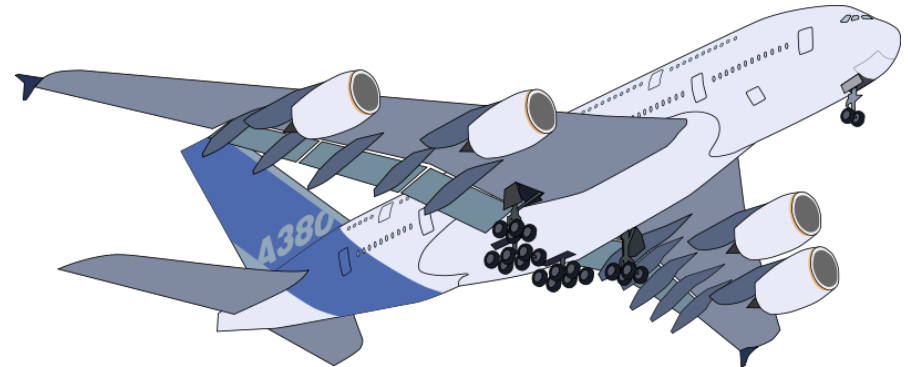

NoC-based Multi-Core Processors

... with a Tiler TILEPro64.

Why?

- Network-On-Chip (NoC) is a scalable on-chip interconnect
- Many cores: 64 cores (100 cores)
- Distributed memory

Our Research focus:

- Dynamic Reconfiguration of software on multi-core processors with adaptive partitioning

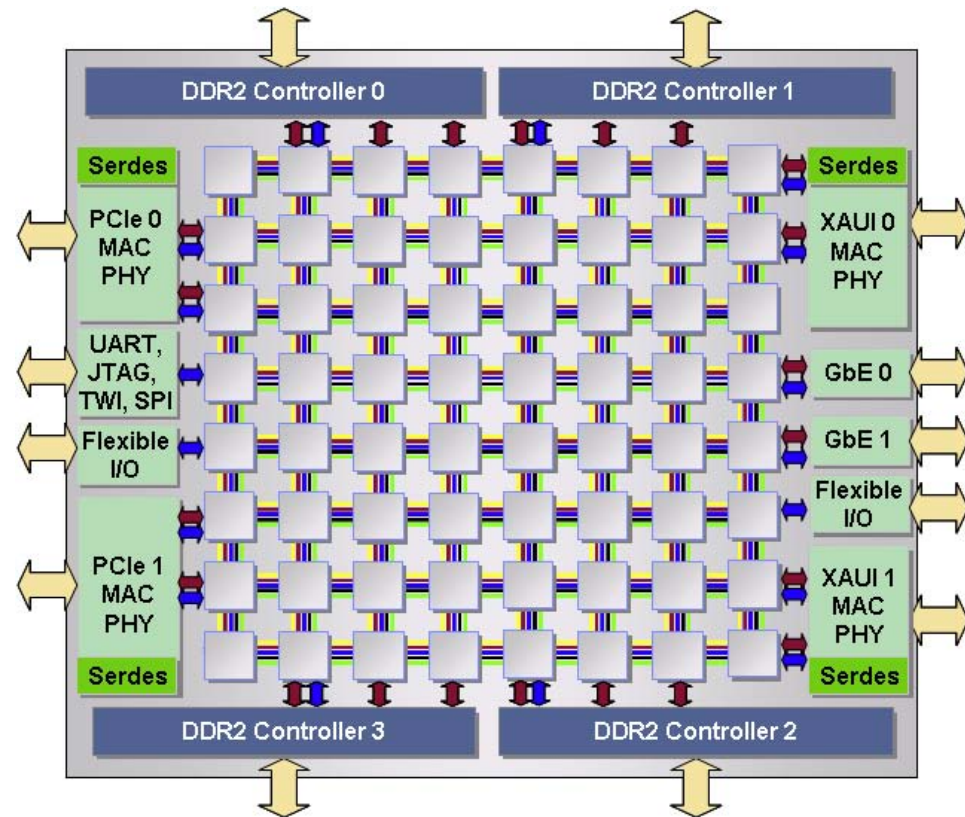

Towards Adaptive Partitioning

- State-of-Practice:
 - static/fixed scheduling and fixed allocation of partitions at design time
- Our research direction:
 - Combine critical, non-critical, synchronous and asynchronous tasks/partitions on a multi-core processor
 - Shape and size of partitions can be fixed or reconfigured at run-time

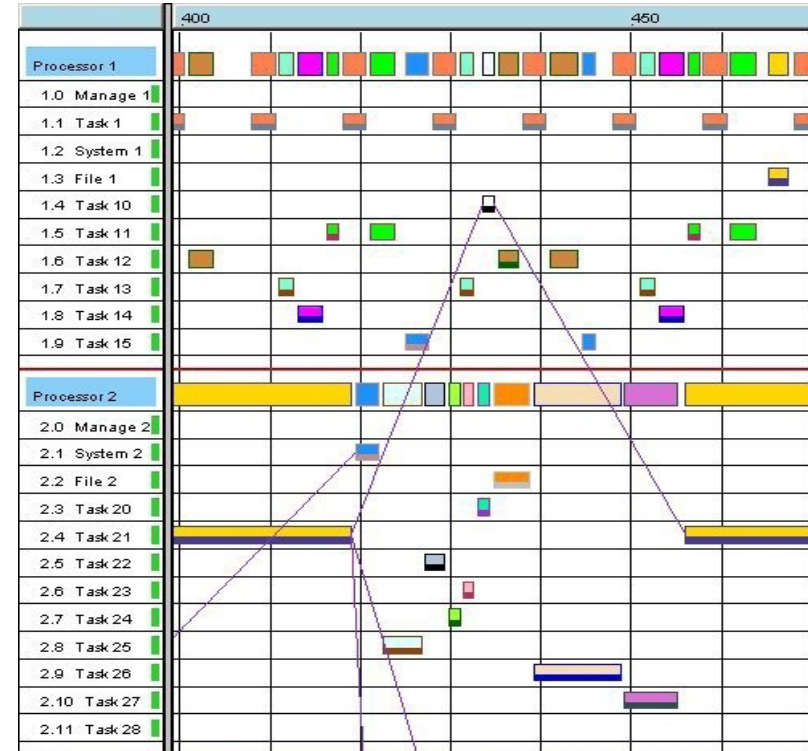

Advantages of Adaptive Partitioning: Reshaping (I)

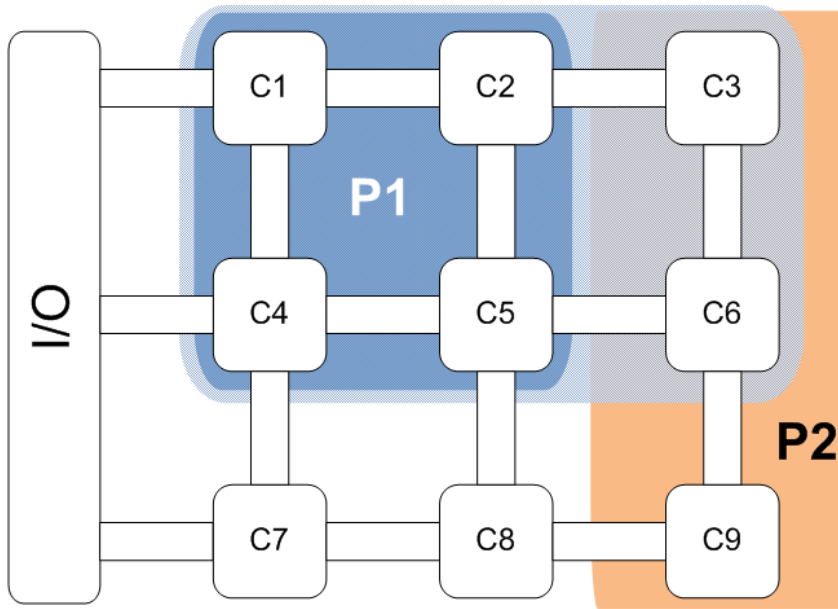

- Partition P2 **is idle**
- Partition P1 extends and temporarily **"borrows" resources** from P2

Advantages of Adaptive Partitioning: Reshaping (II)

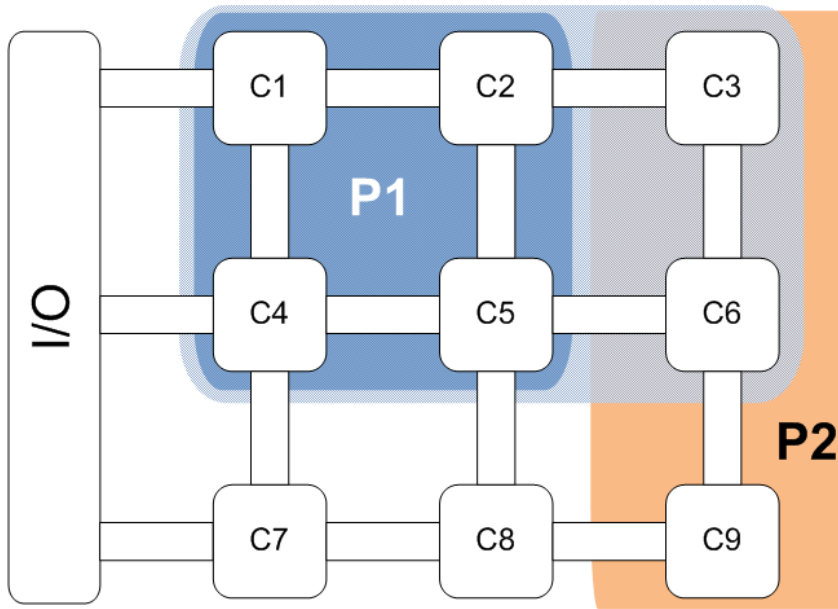

- Partition P2 is idle
- Partition P1 extends and temporarily "borrows" resources from P2

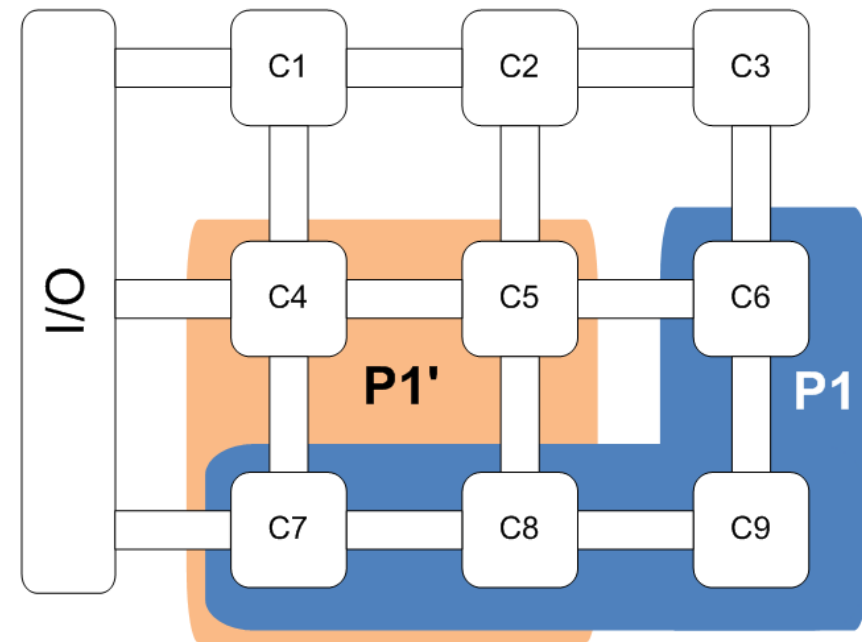

- Partition 1 changes its shape to minimize "hops" between cores

Advantages of Adaptive Partitioning: Relocation (I)

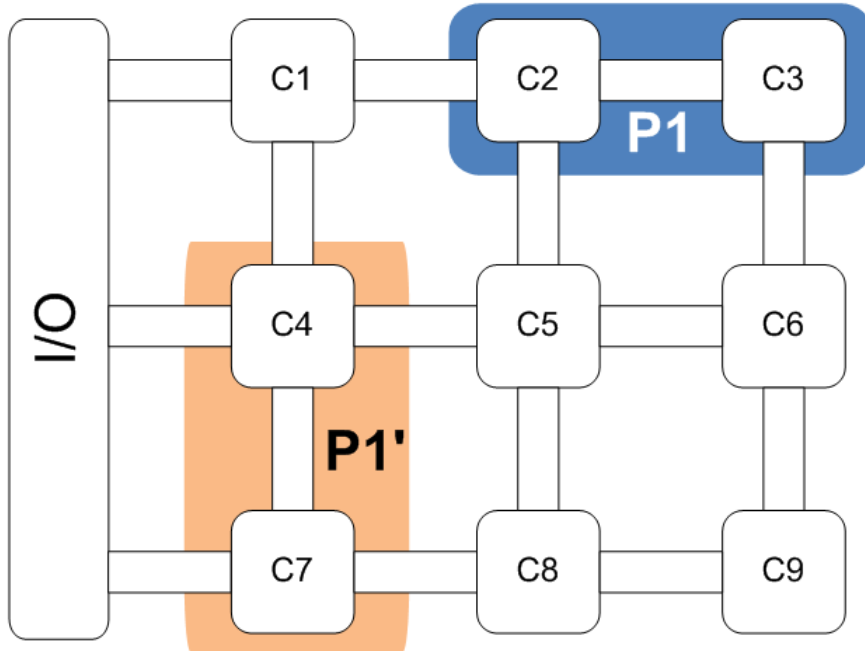

- Partition P1 needs to **access I/O**
- P1 "moves" closer to I/O controller to **minimize path distance and I/O latency**

Advantages of Adaptive Partitioning: Relocation (II)

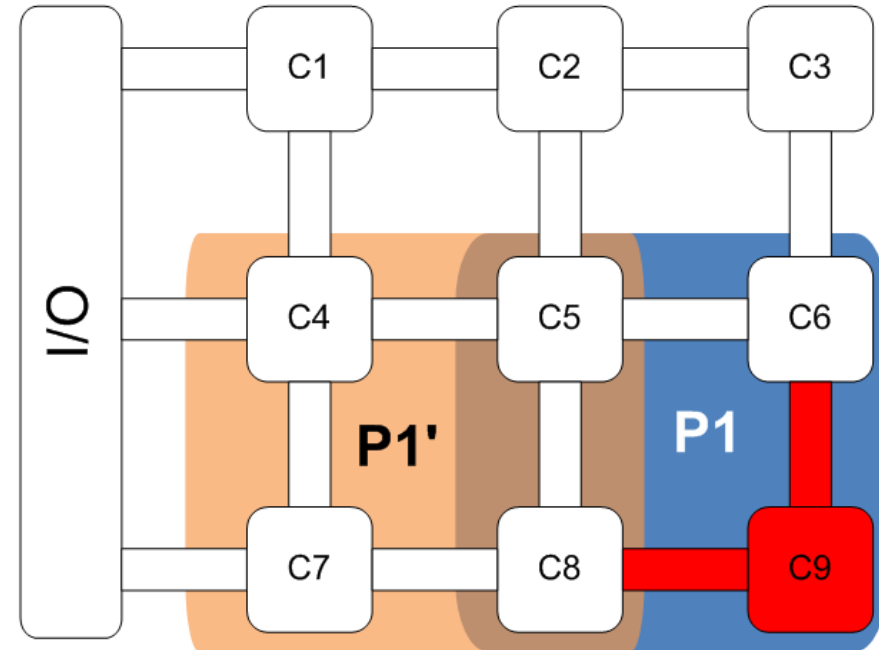
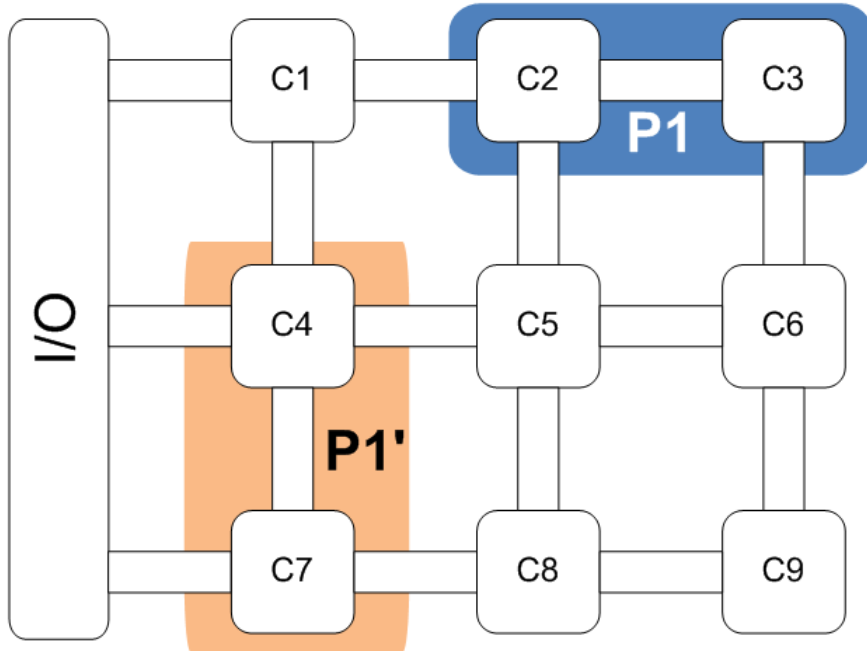

- Partition P1 needs to **access I/O**
- P1 "moves" closer to I/O controller to **minimize path distance and I/O latency**

- Partition P1 uses Core C9, which **exhibits faults**
- Partition P1 moves to a new location

Outlook: Current Research at FIRST

- Migration of partitions on a NoC-based multi-core processor
 - Task and data migration mechanisms (predictability, impact on timing)
 - Coordination pattern (master/slave, distributed, ...)
- Partition isolation
 - How to segregate partitions?
 - How to verify the segregation?
- Partitioning in the engineering process
 - How to incorporate "partitioning" in a distributed engineering process?

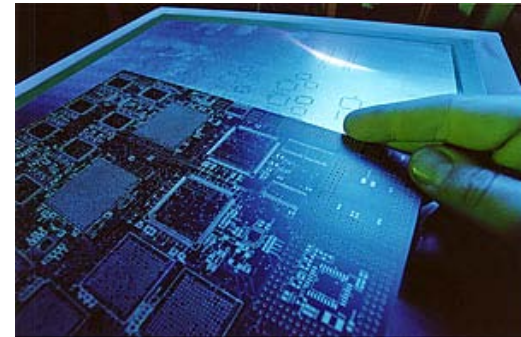

Thank you for your attention