

Kapitel 7: BPMN

Business Process Modeling Notation



Historie

- BPMI.org wurde in 2000 als Non-Profit-Organisation gegründet, treibende Kraft war vor allem die Intalio AG, weitere Mitglieder sind Bea, Fujitsu, IDS Scheer (Aris), Pegasystems, SAP, Staffware, Tibco, IBM (WBI Modeler), Borland (Together) etc.
- In 2006 wurde die BPMI in die OMG integriert.
- BPMN 1.0: final von der OMG akzeptierte Spezifikation, Februar 2006.
- ca. 44 BPMN Implementierungen (Stand 12/2007)
- Mapping BPMN nach BPEL-Übersetzung
- www.bpmn.org



Beispielprozess

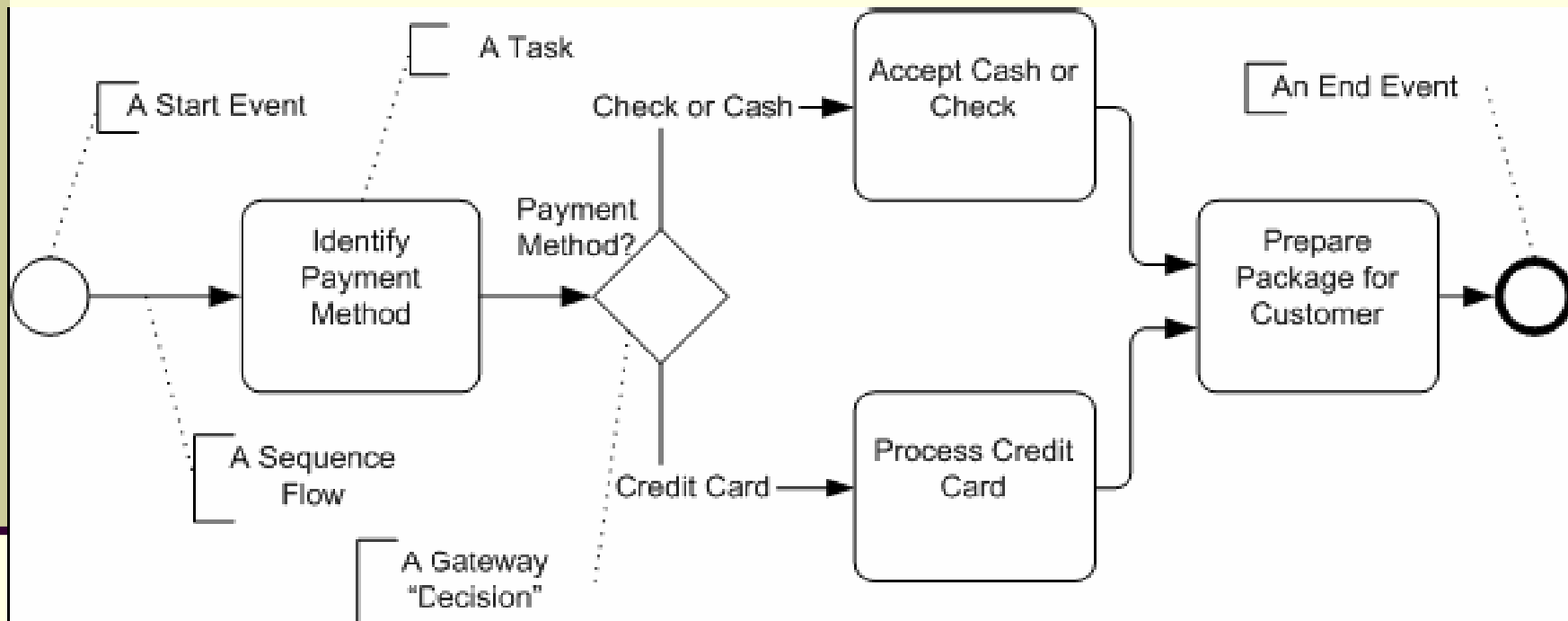

Modellierungskonzepte - Kernelemente

Core Set of BPMN Elements

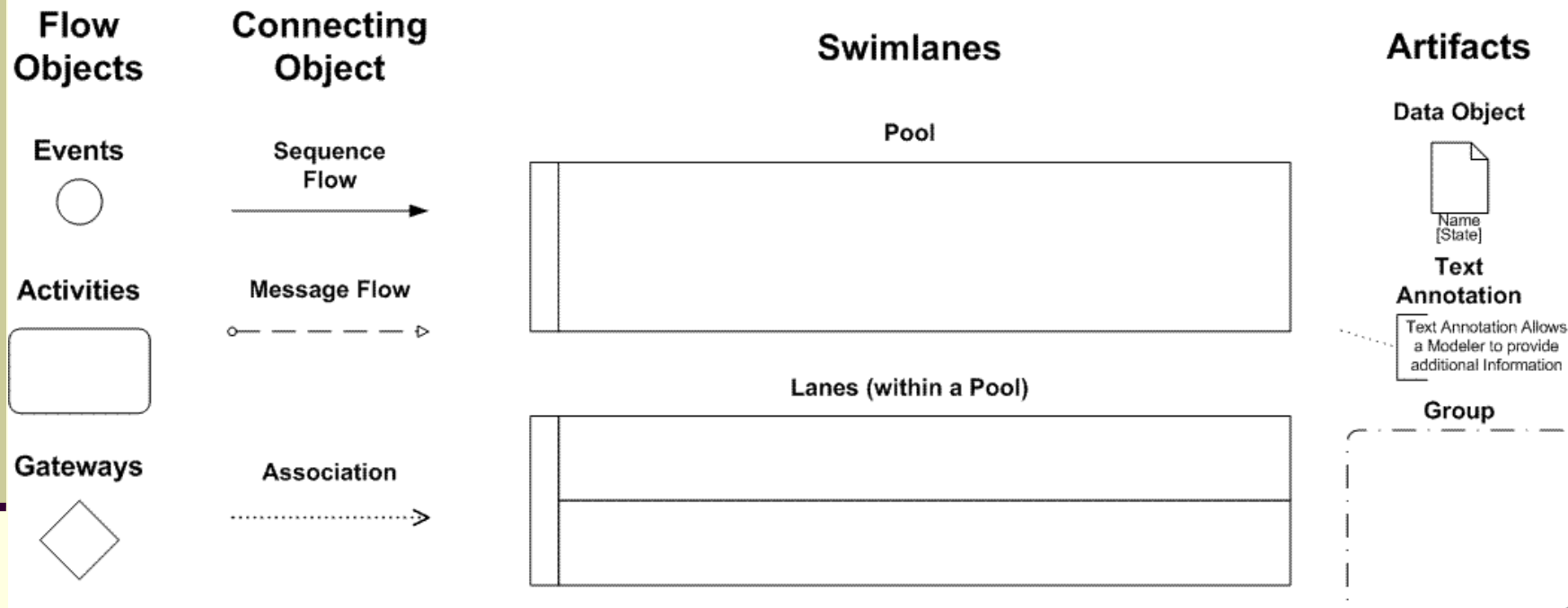

Modellierungskonzepte – Aktivitäten 1

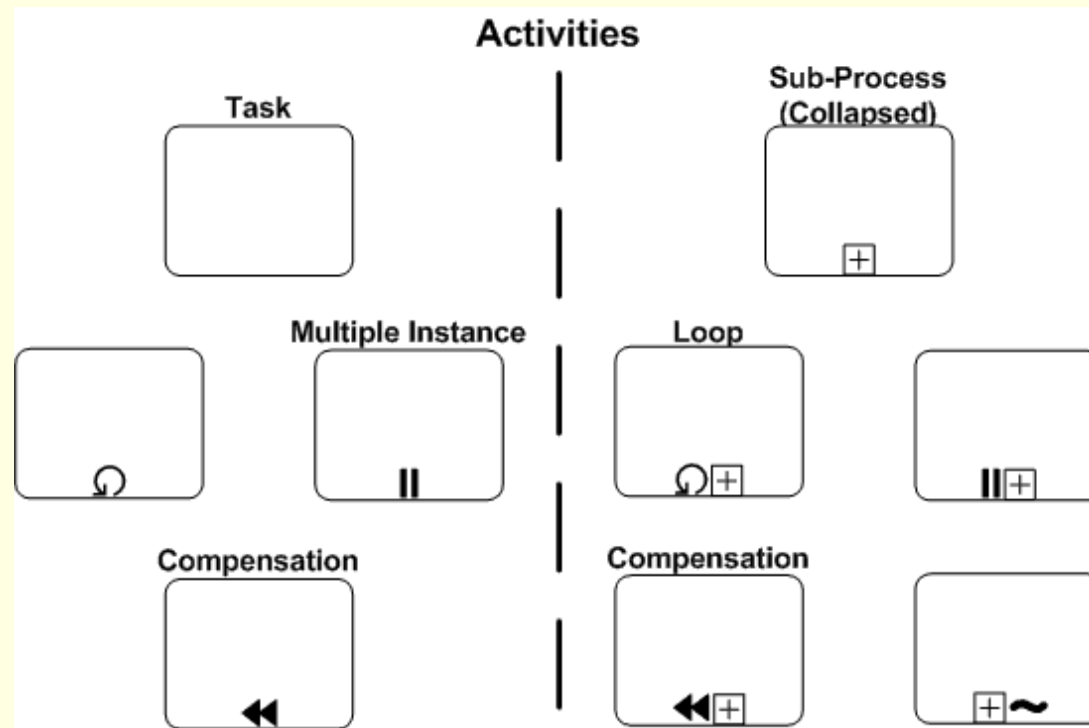

Modellierungskonzepte – Aktivitäten 2

Sub-Process
(Expanded)

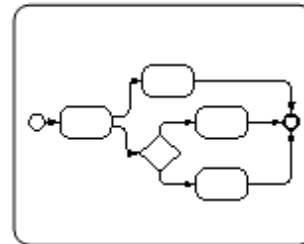

Loop

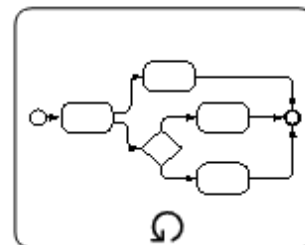

Multiple Instance

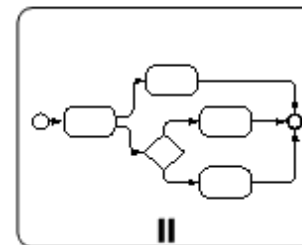



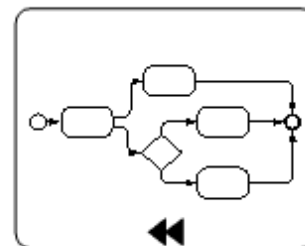



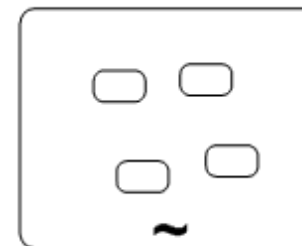

















Compensation



Ad-Hoc



Modellierungskonzepte – Events

	Events		
	Start	Intermediate	End
			
	Event Types		
Message			
Timer			
Error			
Cancel			
Compensation			
Rule			
Link			
Terminate			
Multiple			



Modellierungskonzepte – Events

- Ein Event ‚passiert‘ während des Ablaufs eines Geschäftsprozesses
- Events haben Einfluss auf den Ablauf und haben eine Wirkung (Trigger) oder einen Einfluss auf den Ablauf (Ergebnis).
- Es gibt drei Typen von Events, je nachdem zu welchem Zeitpunkt sie auftauchen können: Start-Event, Zwischen-Event oder End-Event.
- Events können an verschiedenen Stellen der Ablaufbeschreibung integriert werden:
 - als Elemente des Ablaufs
 - an Aktivitäten
 - an Gruppen



Modellierungskonzepte – Verknüpfungen

Connections

Sequence Flow

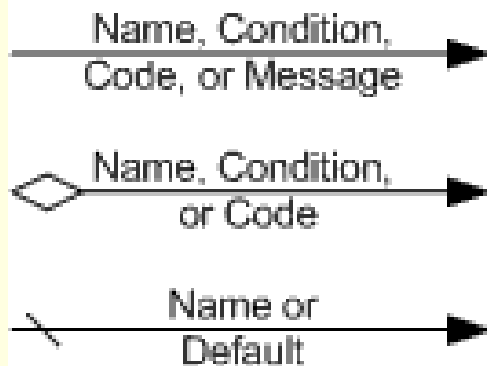

Message Flow



Association



Modellierungskonzepte – Gateways

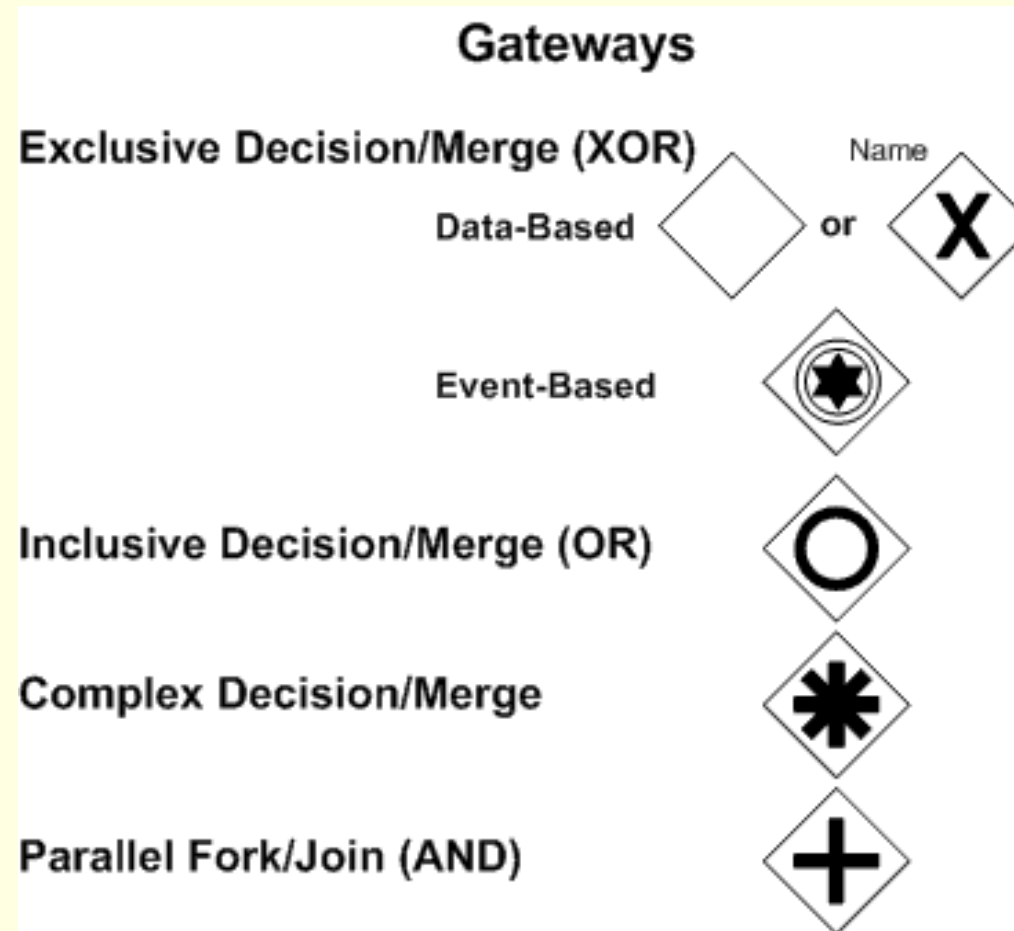

Modellierungskonzepte – Zusätze

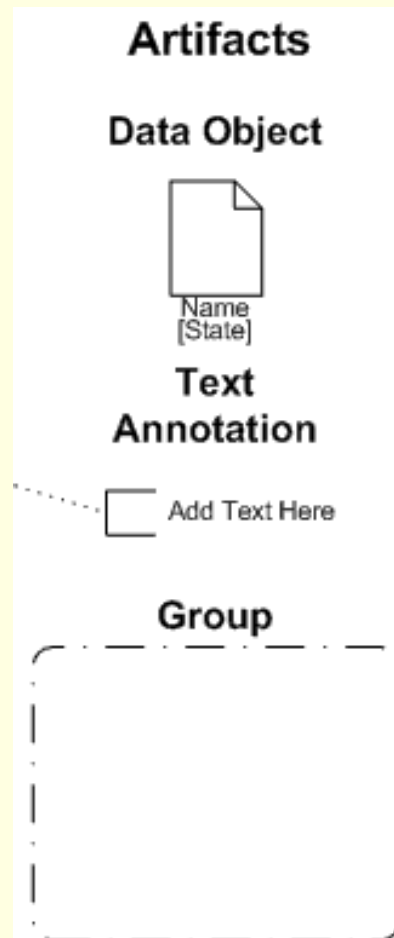

Modellierungskonzepte – Swimlanes

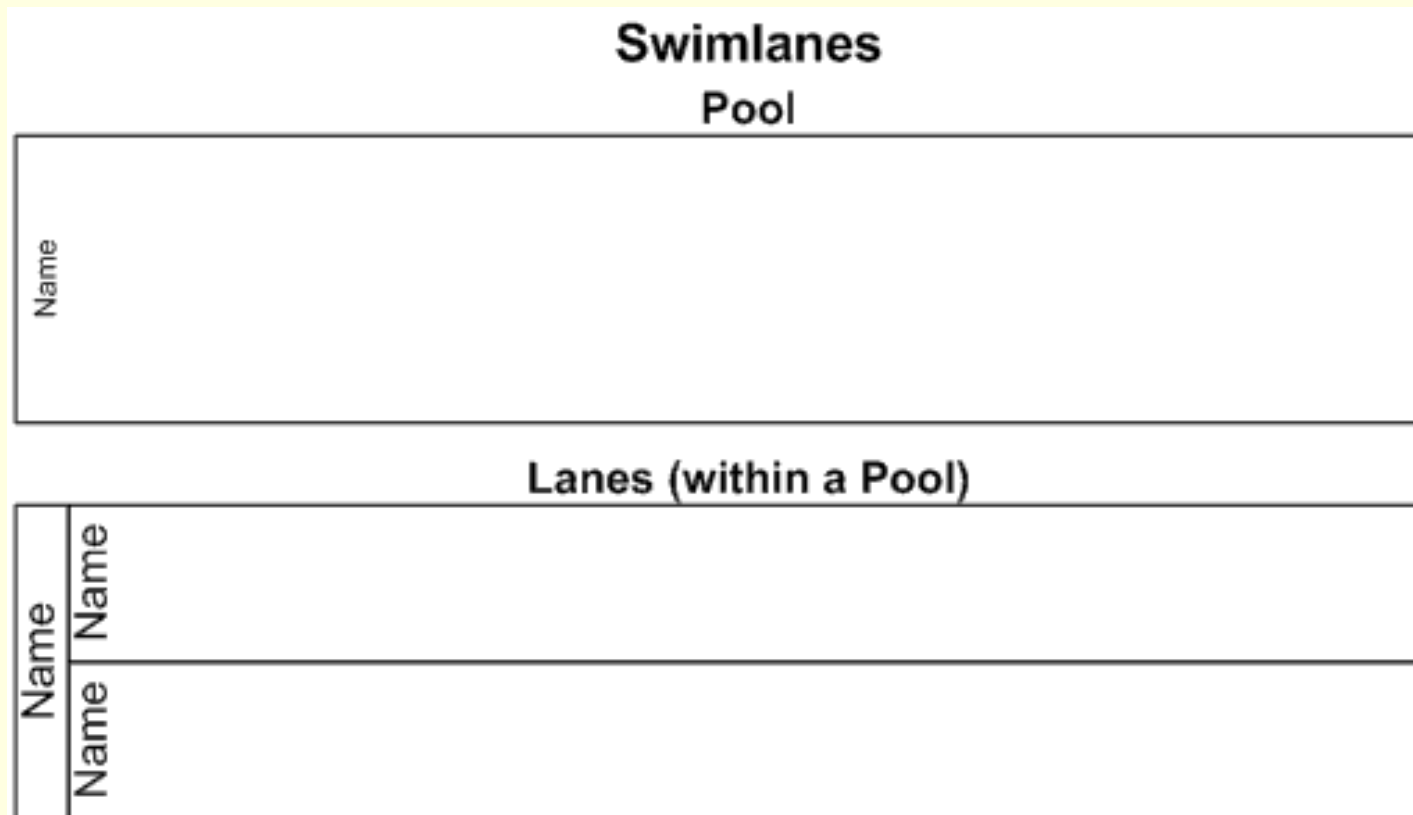

Ausschnitt aus Beispielprozess

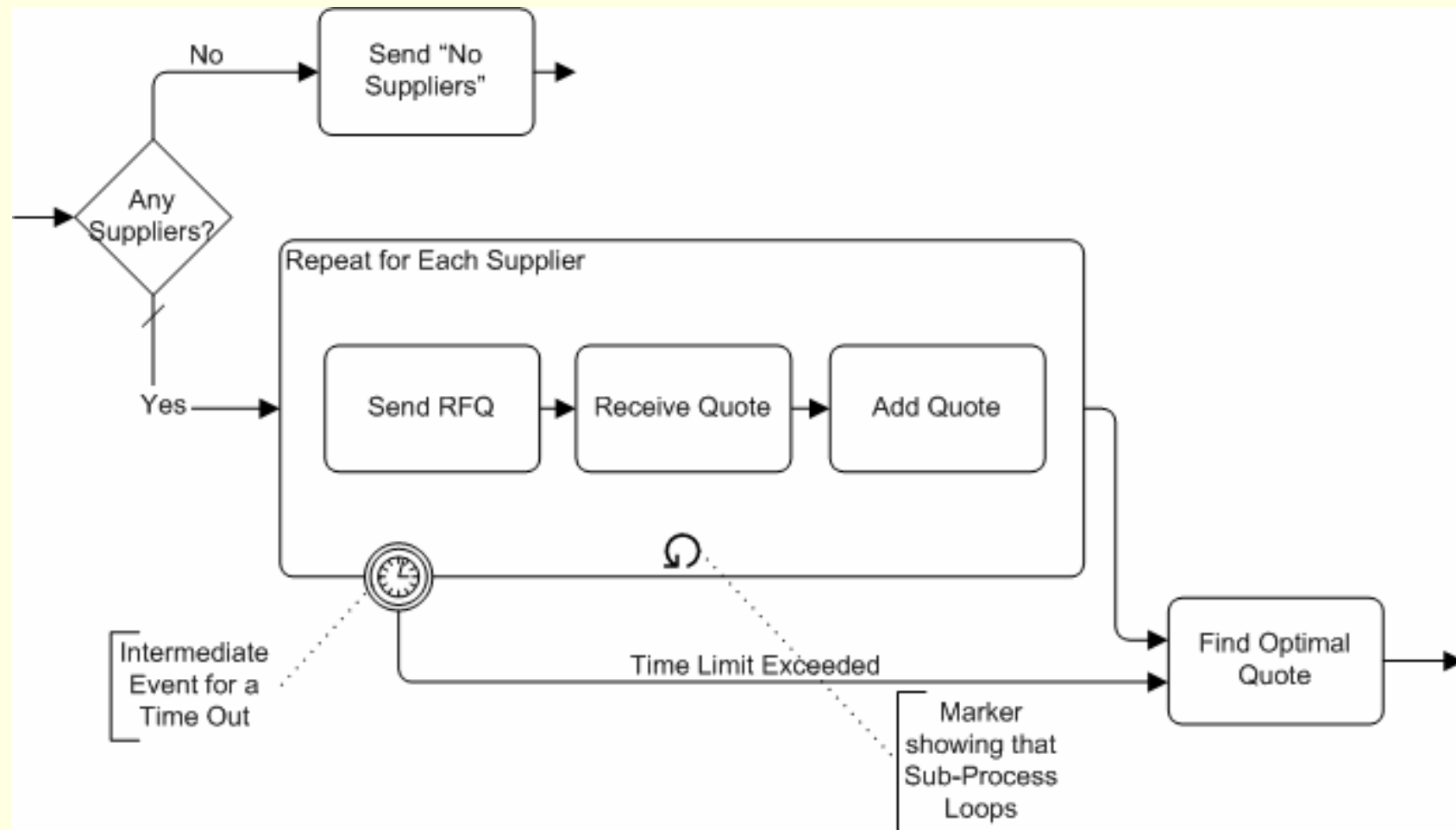

Beispielprozess mit Pools

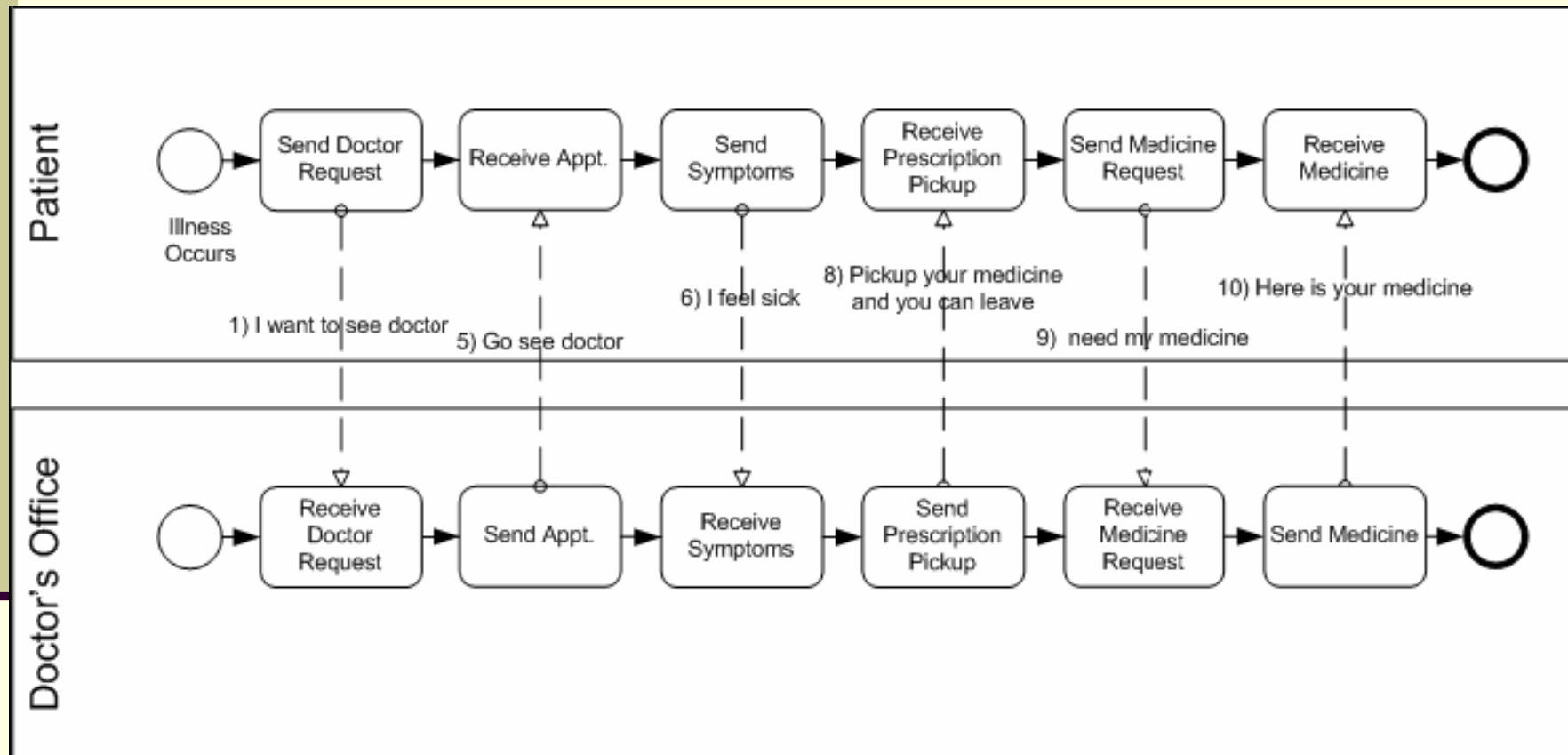

Beispielprozess mit Swimlanes

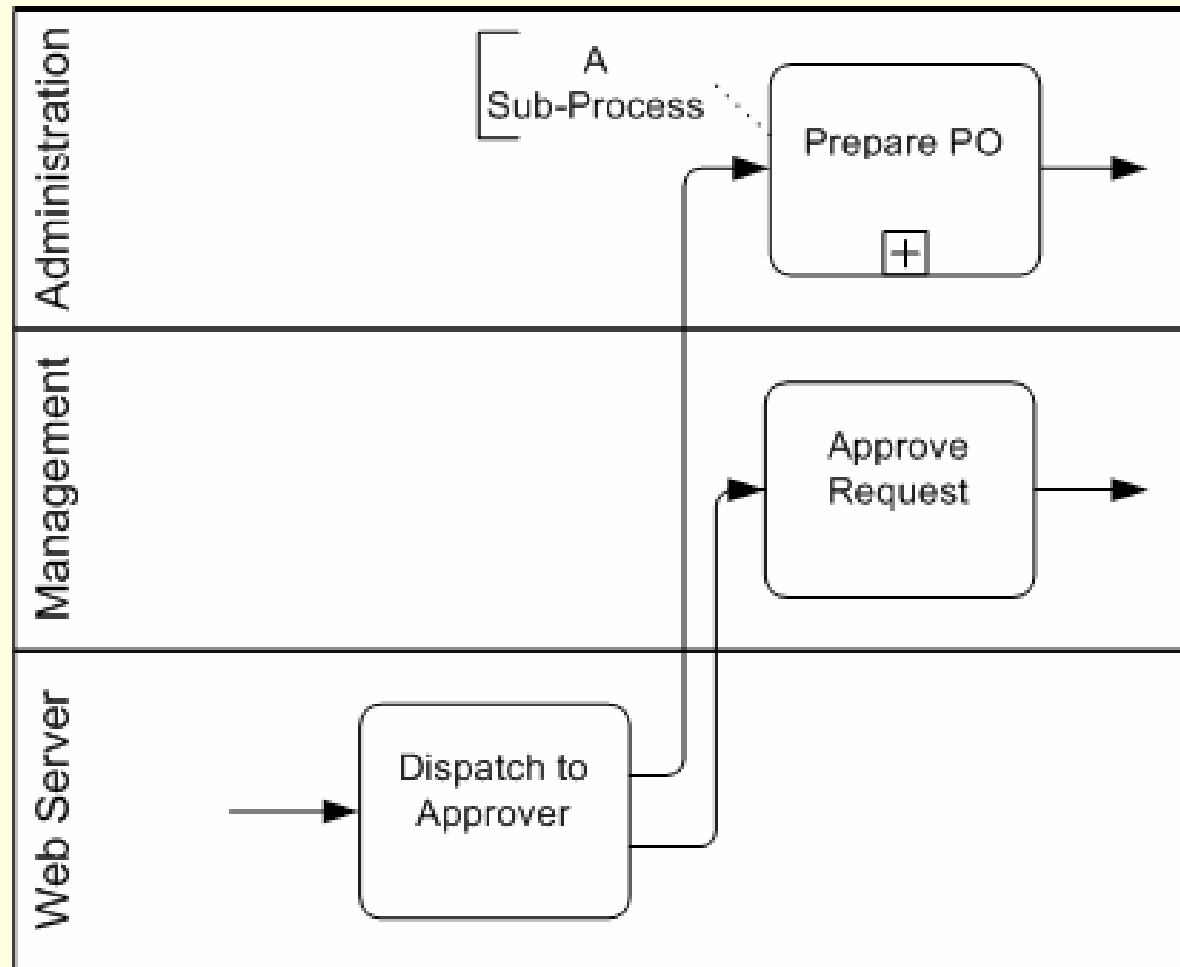

Modellierung eines kollaborativen Prozesses - „öffentlicher Prozess“

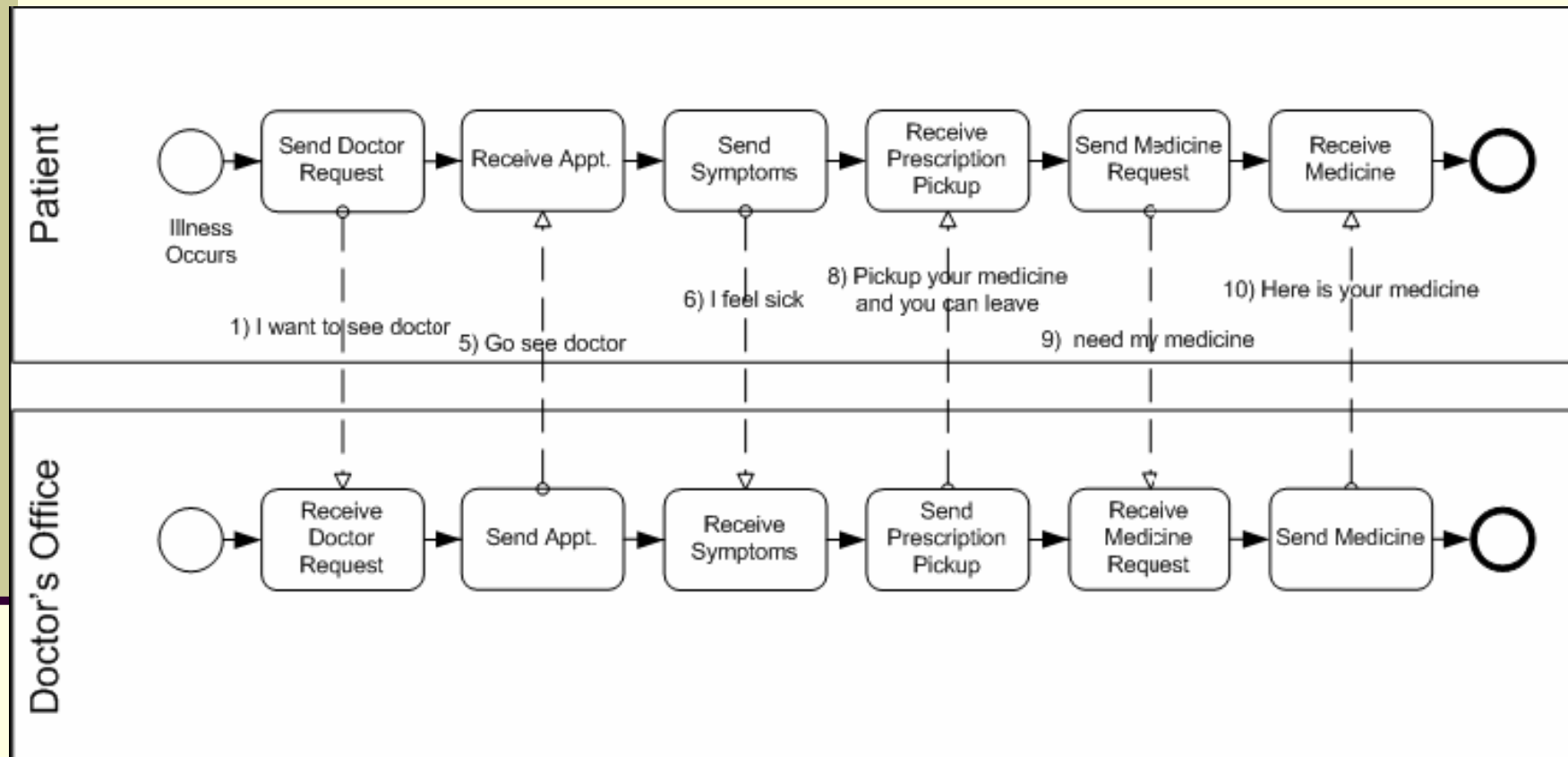

BPMD mit Annotationen zur Abbildung BPMN nach BPEL4WS (WS-BPEL)

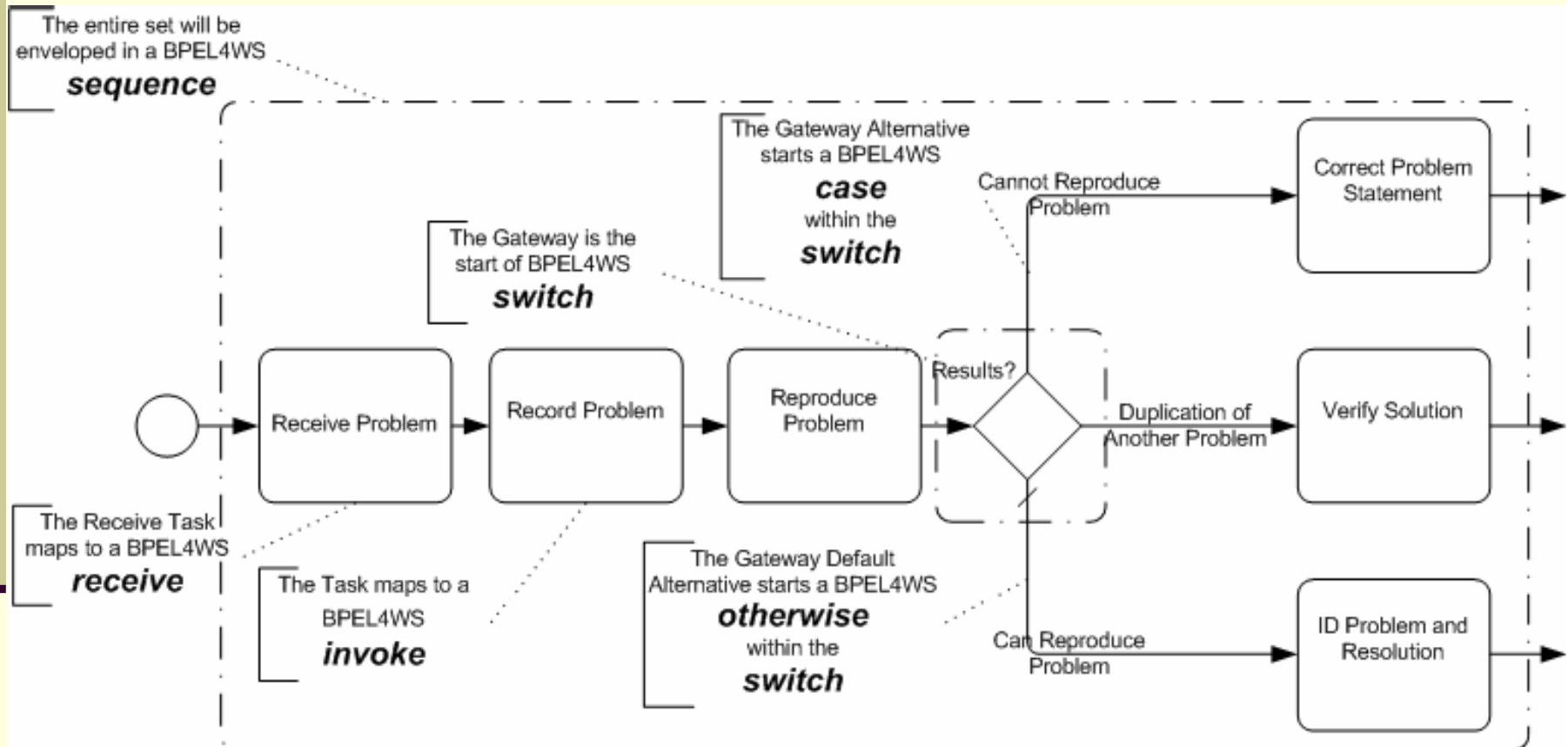

BPEL-Prozess mit IBM Websphere

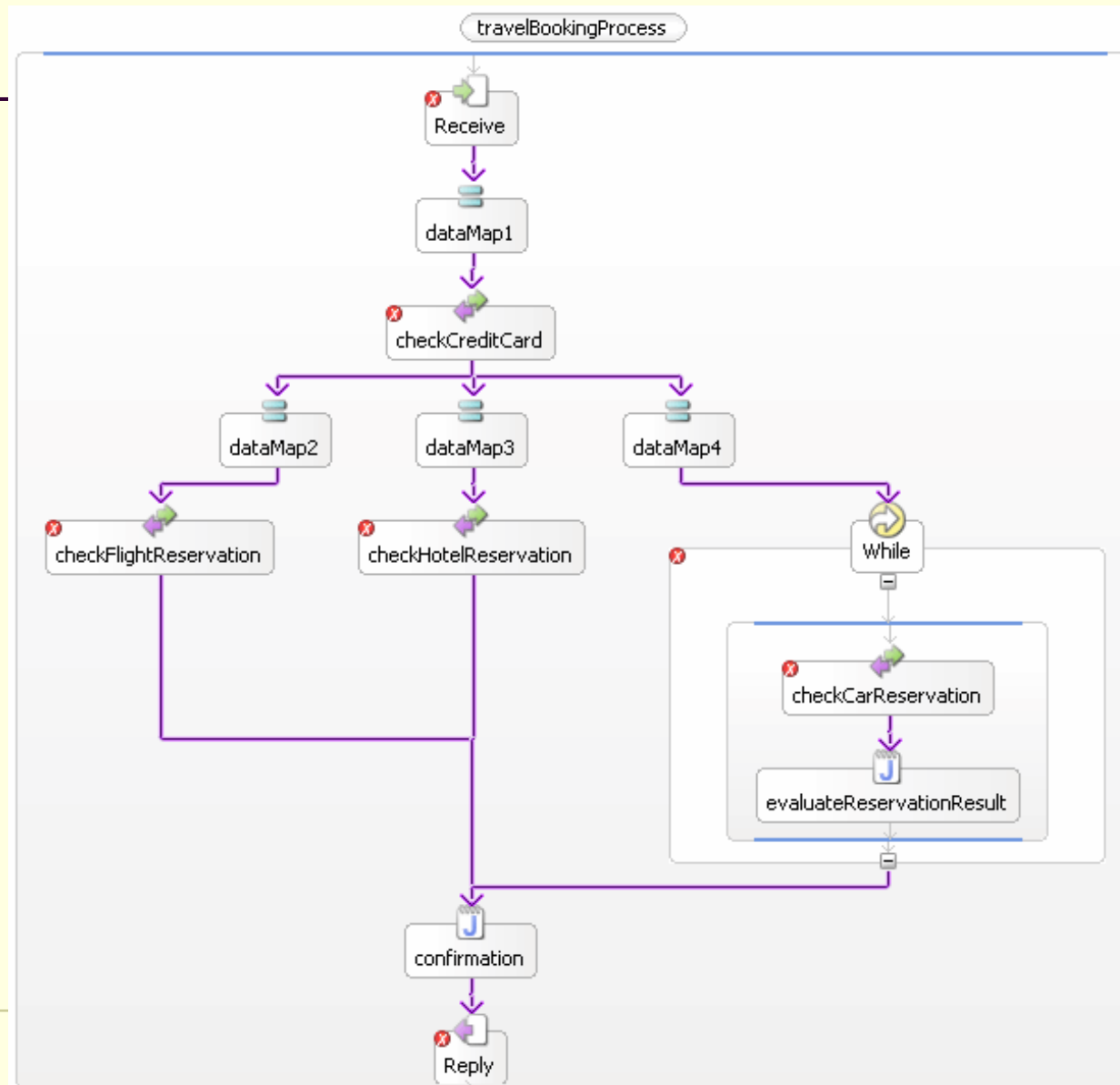

Literaturhinweise

- Stephen A. White: introduction to BPMN.
<http://www.bpmn.org/>
- Literaturhinweis zu bpml, die BPMN aufgenommen haben.



Exemplarische Fragen Kapitel 7

- Auf welcher Modellierungsebene wird BPMN eingesetzt?
- Welches sind die wichtigsten Modellierungskonstrukte BPMN?
- Wozu werden ‚swim lanes‘ benutzt?
- Welche Aspekte werden von BPMN unterstützt?
- Modellieren Sie eine Ablaufanwendung mit BPMN.

